



### EMC compact sub-unit, 3 U

- fits all series-245, 270 and 271 sub-racks
- EMC-compliant design
- with side grooves for EMC contact gaskets
- rear plug-in connection for contact in compliance with DIN 41612



### Specifications

#### Application:

for one PCB 100mm x 160mm

#### Material/finish:

- Front panel: aluminium, 2.5mm  
anodized front  
transparent chromated  
rear
- Side section: aluminium extrusion  
transparent chromated
- Cover hood: aluminium, 1.5mm
- Handle: plastic with aluminium  
strip

#### Delivery:

not assembled

**Note:** See page 75 for matching contact gaskets

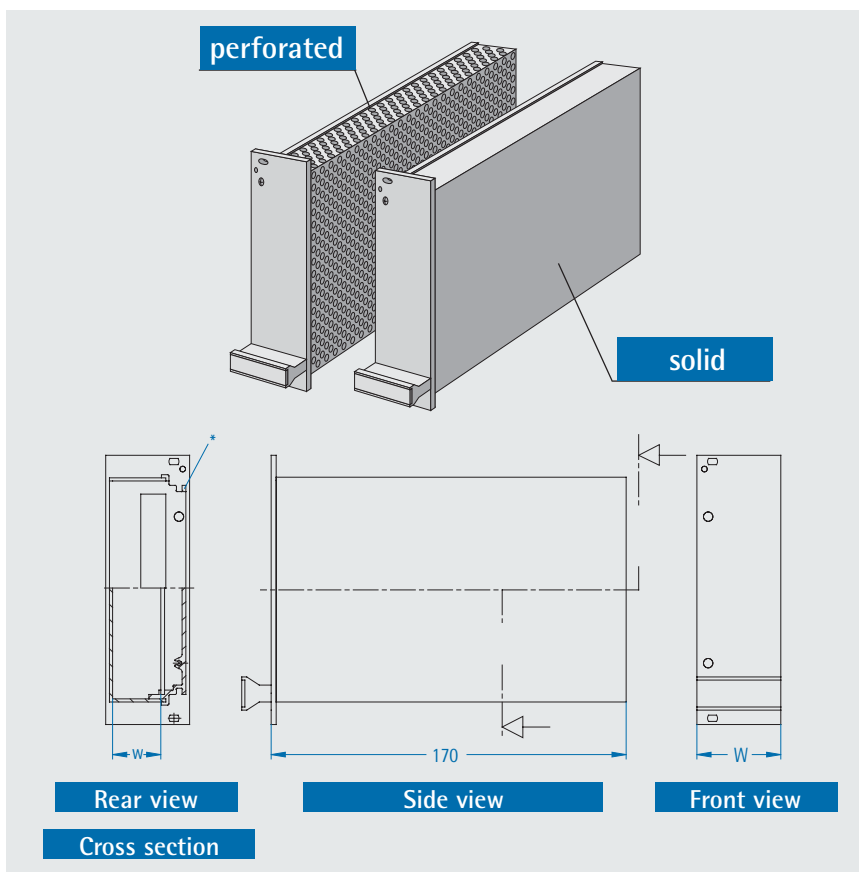

**\*Note:** left groove ensures that the PCB is in the correct position

### Included in delivery

Item	Pc.	Description
1	1	Front panel with groove for EMC contact gasket
2	1	Side extrusion
3	1	Cover
4	1	Handle
5		Assembly material

### Order information

HP	Width W mm	Width w mm	Part no.	
			solid	perforated
6 HP	30,2	22,5	24-7921-55	24-7931-55
8 HP	40,3	32,6	24-7923-55	24-7933-55
10 HP	50,4	42,8	24-7925-55	24-7935-55



### EMC sub-unit, 3 U/6 U

- fits all series-245, 270 and 271 sub-racks
- EMC-compliant design
- with side grooves for EMC contact gaskets
- rear plug-in connection for contact in compliance with DIN 41612
- all components are connected with each other conductively

### Specifications

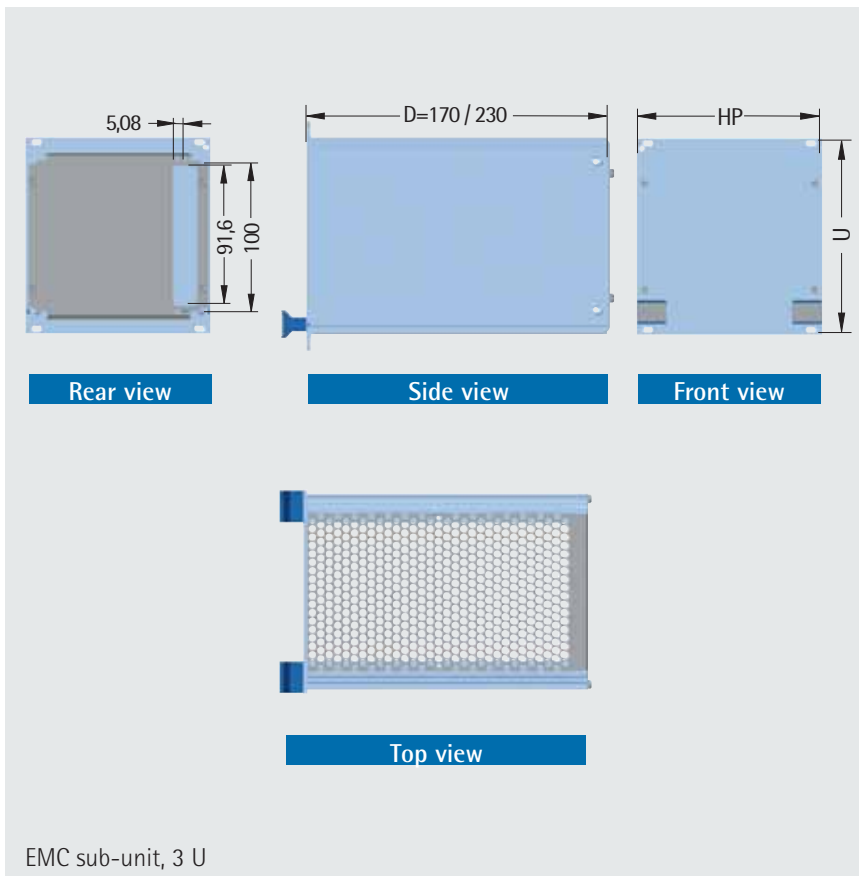

#### Application:

for PCB

**3 U:** 100 x 160mm or 100 x 220mm

**6 U:** 233.35 x 160 or 233.35 x 220mm  
with plug-in connector in compliance with DIN 41612

#### Material/finish:

Front panel: aluminium, 2.5mm  
anodized front  
transparent chromated rear

Side section: aluminium extrusion  
transparent chromated

Rear panel: sheet steel, 1.5mm  
galvanized and blue pas-sivated

Handle: plastic with aluminium  
strip

Cover panels: aluminium  
transparent chromated

#### Delivery:

not assembled

**Note:** left groove ensures that the PCB is in the correct position



## Specifications

### Included in delivery

Item	Pc.	Description
1	1	Front panel with groove for EMC contact gaskets
2	2	Side extrusion
3	1	Rear panel
4	1	Handle*
5	2	Cover panels, perforated
6		Assembly material

\*Note: The handle is divided in units of 2 x 4 HP at 16 HP and greater.

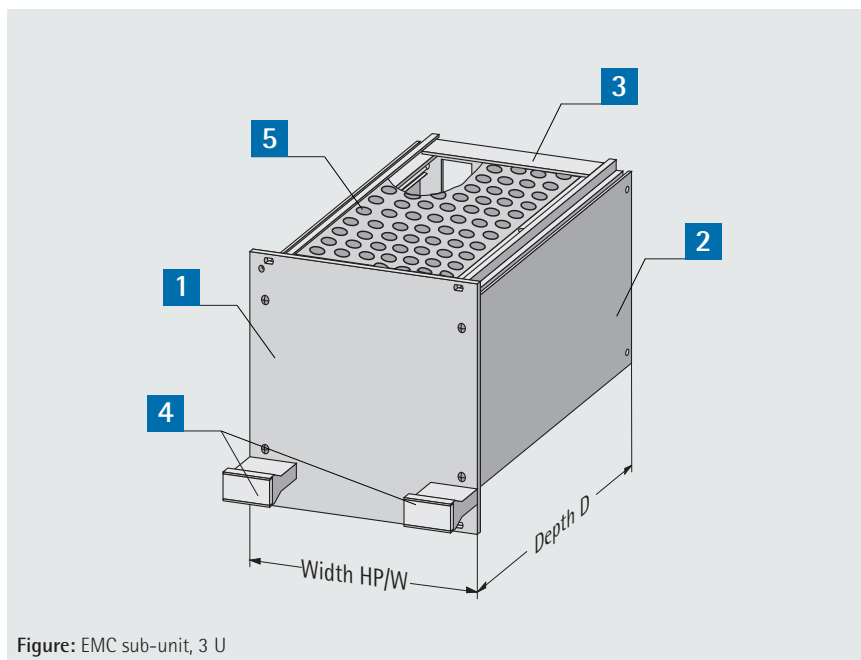

Figure: EMC sub-unit, 3 U

### Order information

HP	Part no. 3 U		Part no. 6 U	
	D = 170 mm	D = 230 mm	D = 170 mm	D = 230 mm
12	24-7062-55	24-7162-55	24-7562-55	24-7662-55
14	24-7064-55	24-7164-55	24-7564-55	24-7664-55
21	24-7071-55	24-7171-55	24-7571-55	24-7671-55
24	24-7074-55	24-7174-55	24-7574-55	24-7674-55
28	24-7078-55	24-7178-55	24-7578-55	24-7678-55
42	24-7092-55	24-7192-55	24-7592-55	24-7692-55

### Accessories

#### EMC contact gasket

- fits in the side grooves in the sub-unit front panel

U	Length mm	Part no. (1 piece)
3	97	671-184
6	232	671-185

Note: See page 67 for front panel screws.

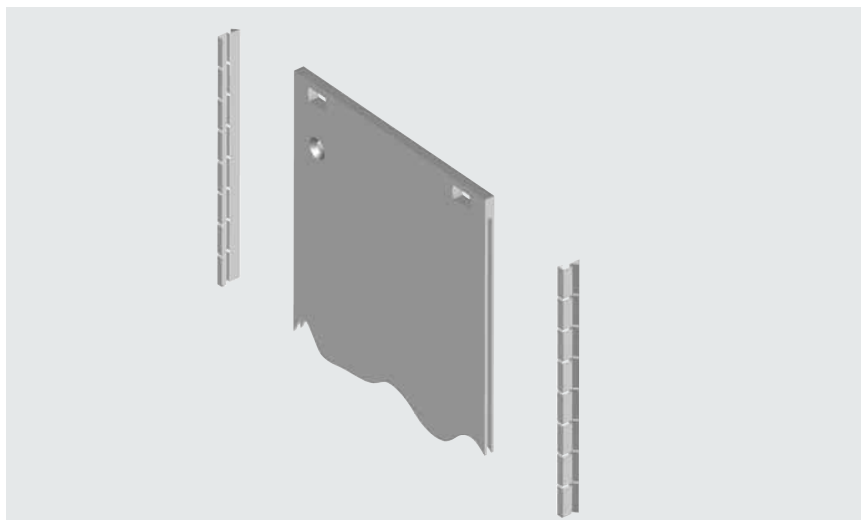



**Sub-unit 3 U with solid sides**

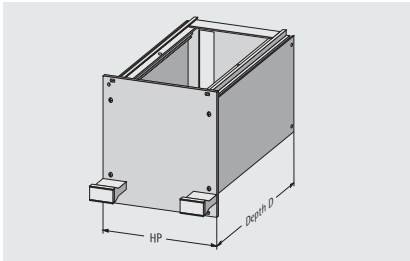

**Included in delivery**

Item	Pc.	Description
1	1	Front panel with plastic handlebar*
2	1	Rear panel
3	2	Aluminium extrusions
4		Assembly material

HP	Part no.	
	D = 170 mm	D = 230 mm
12	247-062	247-162
14	247-064	247-164
21	247-071	247-171
24	247-074	247-174
28	247-078	247-178
42	247-092	247-192

**Sub-unit 3 U with open sides**

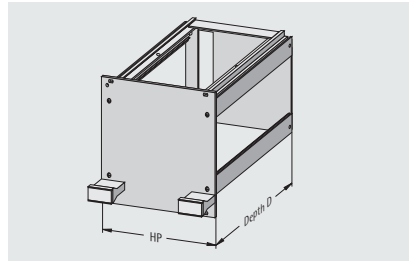

**Included in delivery**

Item	Pc.	Description
1	1	Front panel with plastic handlebar*
2	1	Rear panel
3	4	Aluminium extrusions
4		Assembly material

HP	Part no.	
	D = 170 mm	D = 230 mm
12	247-262	247-362
14	247-264	247-364
21	247-271	247-371
24	247-274	247-374
28	247-278	247-378
42	247-292	247-392

**Sub-unit 3 U**

- with solid or open sides

**Application:**

for **one PCB** 100 x 160 mm or 100 x 220 mm with connector in compliance with DIN 41612

**Material/finish:**

Front panel: aluminium, 2.5mm anodized

Side extrusion: anodized aluminium

Rear panel: sheet steel, 1.5mm galvanized and blue passivated

Handle: plastic with aluminium strip

**Delivery:**

not assembled

Special sizes or sub-units with special treatments and printing are available on request.

**\*Note:** The handle is divided in units of 2 x 4 HP at 16 HP and greater.

**Expansion parts**

**Side panel, perforated**

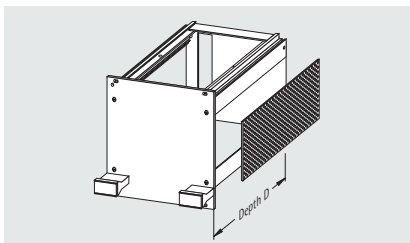

**Included in delivery**

Item	Pc.	Description
1	1	Side panel

Part no.	
D = 170 mm	D = 230 mm
248-402	248-502

**Finish:**

transparent chromated

**Material:**

perforated aluminium panel

**Top or bottom panel**

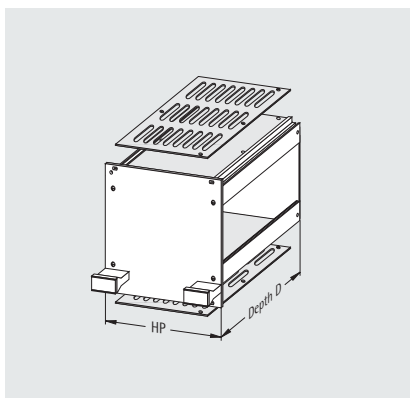

**Included in delivery**

Item	Pc.	Description
1	1	Top or bottom panel

HP	Part no. solid		Part no. perforated	
	D = 170 mm	D = 230 mm	D = 170 mm	D = 230 mm
12	24-8112-07	24-8312-07	24-8112-05	24-8312-05
14	24-8114-07	24-8314-07	24-8114-05	24-8314-05
21	24-8121-07	24-8321-07	24-8121-05	24-8321-05
24	24-8124-07	24-8324-07	24-8124-05	24-8324-05
28	24-8128-07	24-8328-07	24-8128-05	24-8328-05
42	24-8142-07	24-8342-07	24-8142-05	24-8342-05

**Finish:**

transparent chromated

**Material:** aluminium 1,5 mm



### Sub-unit 6 U

- with solid or open sides

**Application:**

for one PCB 233.35 x 160 mm or 233.35 x 220 mm with connector in compliance with DIN 41612

**Material/finish:**

Front panel: aluminium, 2.5mm anodized

Side extrusion: anodized aluminium

Rear panel: sheet steel, 1.5mm galvanized and blue pas-sivated

Handle: plastic with aluminium strip

**Delivery:**

not assembled

Special sizes or sub-units with special treatments and printing are available on request.

**\*Note:** The handle is divided in units of 2 x 4 HP at 16 HP and greater.

### Sub-unit 6 U with solid sides

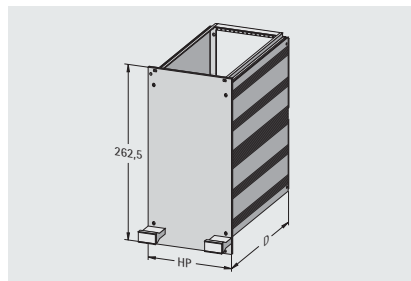

**Included in delivery**

Item	Pc.	Description
1	1	Front panel with plastic handlebar*
2	1	Rear panel
3	2	Aluminium extrusions
4		Assembly material

HP	Part no.	
	D = 170 mm	D = 230 mm
12	24-7562-50	24-7662-50
14	24-7564-50	24-7664-50
21	24-7571-50	24-7671-50
24	24-7574-50	24-7674-50
28	24-7578-50	24-7678-50
42	24-7592-50	24-7692-50

### Sub-unit 6 U with open sides

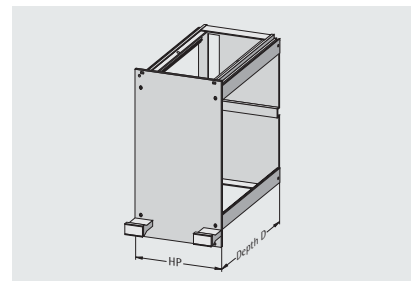

**Included in delivery**

Item	Pc.	Description
1	1	Front panel with plastic handlebar*
2	1	Rear panel
3	4	Aluminium extrusions
4		Assembly material

HP	Part no.	
	D = 170 mm	D = 230 mm
12	247-562	247-662
14	247-564	247-664
21	247-571	247-671
24	247-574	247-674
28	247-578	247-678
42	247-592	247-692

### Expansion parts

#### Side panel, perforated

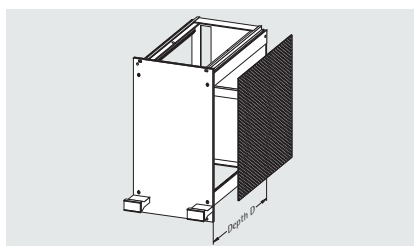

**Included in delivery**

Item	Pc.	Description
1	1	Side panel

Part no.	
D = 170 mm	D = 230 mm
248-394	248-494

**Finish:**

transparent chromated

**Material:**

perforated aluminium panel

#### Top or bottom panel

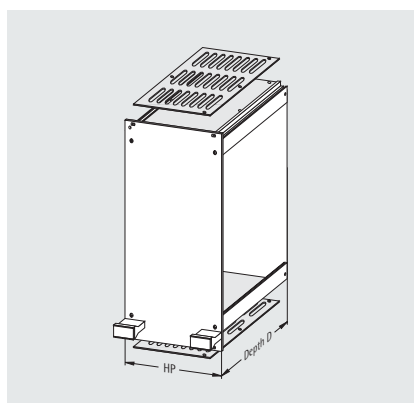

**Included in delivery**

Item	Pc.	Description
1	1	Top or bottom panel

HP	Part no. solid		Part no. perforated	
	D = 170 mm	D = 230 mm	D = 170 mm	D = 230 mm
12	24-8112-07	24-8312-07	24-8112-05	24-8312-05
14	24-8114-07	24-8314-07	24-8114-05	24-8314-05
21	24-8121-07	24-8321-07	24-8121-05	24-8321-05
24	24-8124-07	24-8324-07	24-8124-05	24-8324-05
28	24-8128-07	24-8328-07	24-8128-05	24-8328-05
42	24-8142-07	24-8342-07	24-8142-05	24-8342-05

**Finish:**

transparent chromated

**Material:**

aluminium 1,5 mm



### EMC cassette, 3 U/6 U

- fits all series 245, 270, 271 subracks and desktop enclosures
- EMC-compliant design
- with side grooves for EMC gaskets
- Rear panel can hold several female connectors for internal wiring
- with 1 HP mounting grid for internal card guide



### Specifications

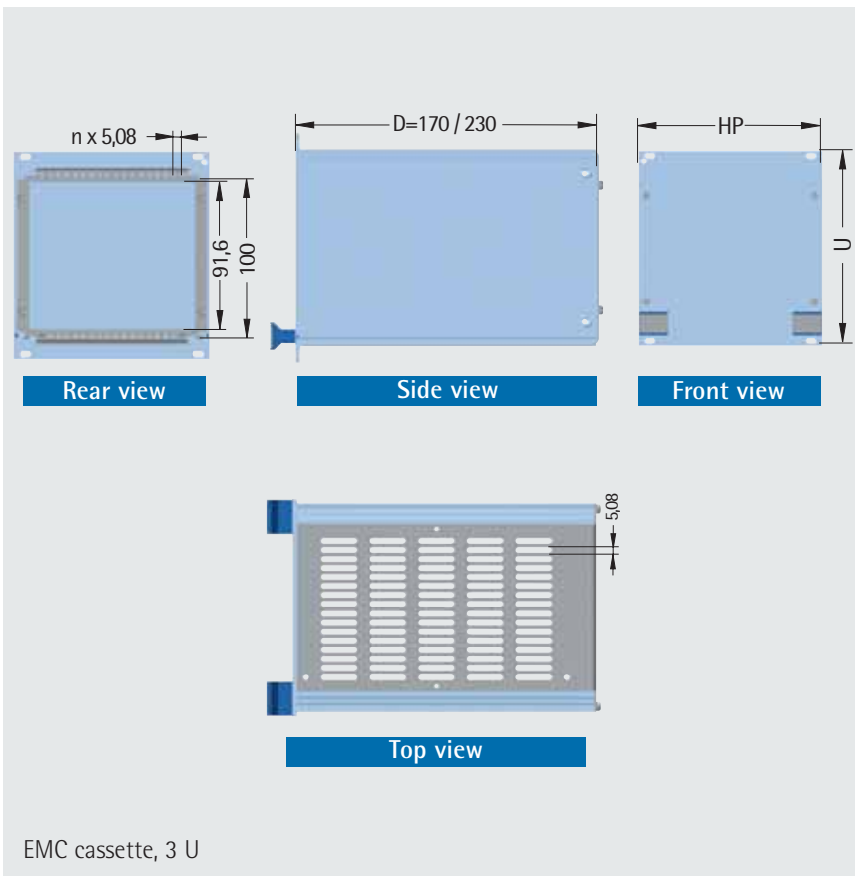

#### Application:

for several PCB's

**3 U:** 100 x 160 mm or 100 x 220 mm

**6 U:** 233.35 x 160 mm or

233.35 x 220 mm

with connector in compliance with DIN 41612

#### Material/finish:

- Front panel: aluminium, 2.5mm anodized front transparent chromated rear
- Side section: aluminium transparent chromated
- Rear panel: sheet steel, 1.5mm galvanized and blue pas-sivated
- Handle: plastic with aluminium strip
- Cover panels: aluminium transparent chromated

#### Delivery:

not assembled

**Note:** left groove ensures that the PCB is in the correct position



## Specifications

### Included in delivery

Item	Pc.	Description
1	1	Front panel with groove for EMC contact gasket
2	2	Side extrusion
3	1	Rear panel
4	1/2	Handle*
5	2	Cover panels
6	1 Satz	Assembly material

\*Note: The handle is divided in units of 2 x 4 HP at 16 HP and greater.

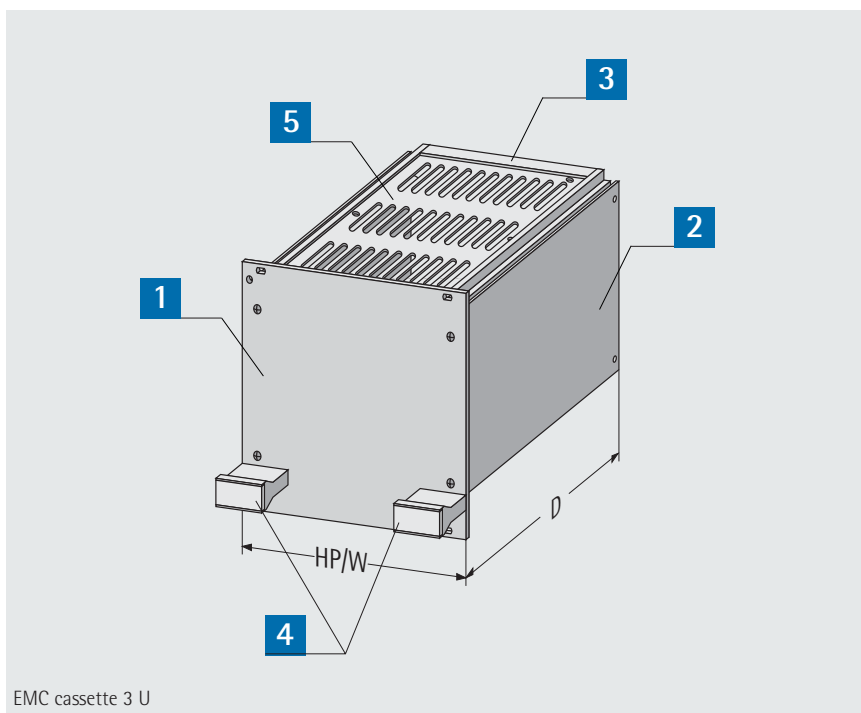

### Order information

HP	W mm	Part no. 3 U		Part no. 6 U	
		D = 170 mm	D = 230 mm	D = 170 mm	D = 230 mm
12	60,6	24-8062-55	24-8162-55	24-8712-55	24-8812-55
14	70,8	24-8064-55	24-8164-55	24-8714-55	24-8814-55
21	106,3	24-8071-55	24-8171-55	24-8721-55	24-8821-55
24	121,5	24-8074-55	24-8174-55	24-8724-55	24-8824-55
28	142,0	24-8078-55	24-8178-55	24-8728-55	24-8828-55
42	213,0	24-8092-55	24-8192-55	24-8742-55	24-8842-55

### Accessories

#### EMC contact gasket

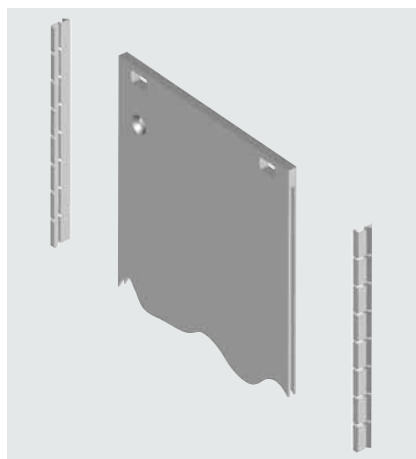

- fits in the side groove of the cassette front panel

U	Length mm	Part no. (1 piece)
3	97	671-184
6	232	671-185

Note: See p. 67 for front panel screws.

#### Internal card guide

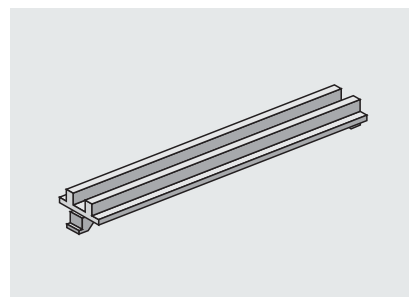

- guides cards inside a cassette

Part no. (1 piece)
250-712



**Cassette 3 U  
with open sides**

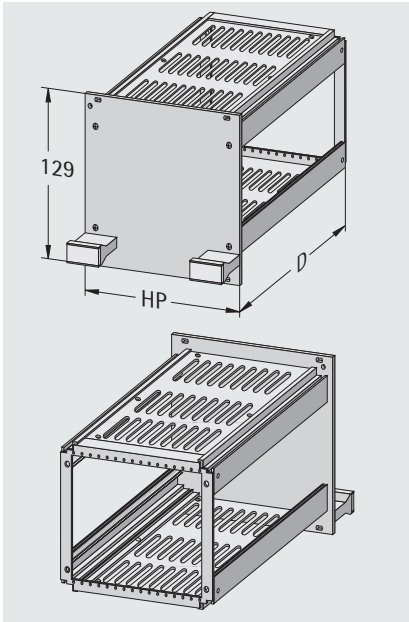

**Cassette 3 U  
with divided front panel**

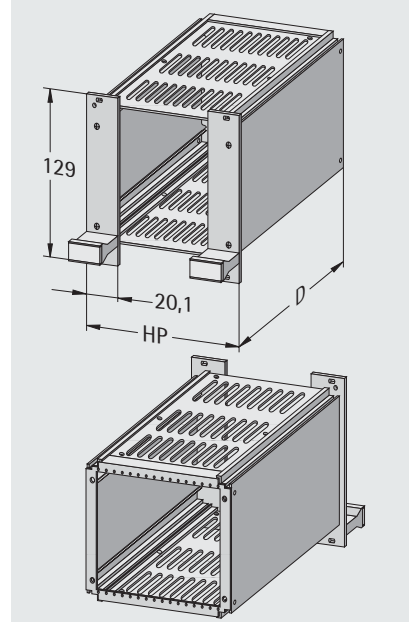

**Cassette 3 U**

- 2 models are available
  - with open sides
  - with divided front panel
- with 1 HP mounting grid for internal card guide

**Material:**

- Front panel: aluminium, 2.5mm anodized
- Side section: anodized aluminium
- Rear panel: sheet steel, 1.5mm galvanized and blue passivated
- Cover panels: aluminium, 1.5mm transparent chromated
- Handle: plastic with aluminium strip

**Delivery:**

not assembled

**Included in delivery**

Item	Pc.	Description
1	1	Front panel with plastic handlebar*
2	1	Rear panel
3	4	Aluminium extrusions
4	2	Top / bottom panel, perforated
5		Assembly material

**Included in delivery**

Item	Pc.	Description
1	2	Front panel with plastic handlebar*
2	1	Rear panel
3	2	Aluminium extrusions
4	2	Top / bottom panel, perforated
5		Assembly material

HP	W mm	Part no.	
		D = 170 mm	D = 230 mm
12	60,6	248-462	248-562
14	70,8	248-464	248-564
21	106,3	248-471	248-571
24	121,5	248-474	248-574
28	142,0	248-478	248-578
42	213,0	248-482	248-592

HP	W mm	Part no.	
		D = 170 mm	D = 230 mm
12	60,6	248-262	248-362
14	70,8	248-264	248-364
21	106,3	248-271	248-371
24	121,5	248-274	248-374
28	142,0	248-278	248-378
42	213,0	248-292	248-382

Special sizes or cassettes with special treatments and printing are available on request.

\*Note: The handle is divided in units of 2 x 4 HP at 16 HP and greater.

**Expansion parts**

**Side panel, perforated**

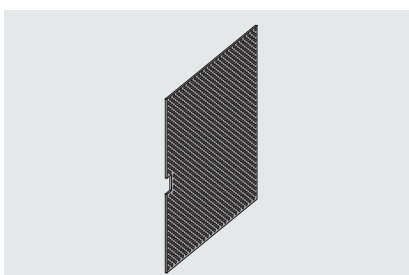

**Finish:**  
transparent chromated

**Material:**  
perforated aluminium panel

U	D mm	Part no.
3	170	248-402
3	230	248-502

**Internal card guide**

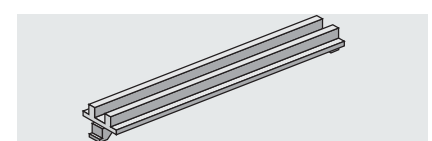

- guides cards inside a cassette

<b>Part no. (1 piece)</b> 250-712
--------------------------------------





### Cassette 6 U

- 2 models are available
  - with open sides
  - with solid sides
- with 1 HP mounting grid for internal card guide

#### Material:

Front panel: aluminium, 2.5mm anodized  
 Side section: anodized aluminium  
 Rear panel: sheet steel, 1.5mm galvanized and blue passivated  
 Cover panels: aluminium, 1.5mm transparent chromated  
 Handle: plastic with aluminium strip

#### Delivery:

not assembled

Special sizes or cassettes with special treatments and printing are available on request.

\*Note: The handle is divided in units of 2 x 4 HP at 16 HP and greater.

### Expansion parts

#### Side panel, perforated

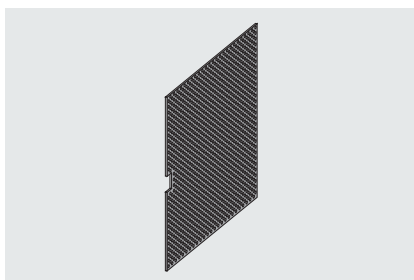

**Finish:**  
transparent chromated

**Material:**  
perforated aluminium panel

U	D mm	Part no.
6	170	248-392
6	230	248-492

### Cassette 6 U with solid sides

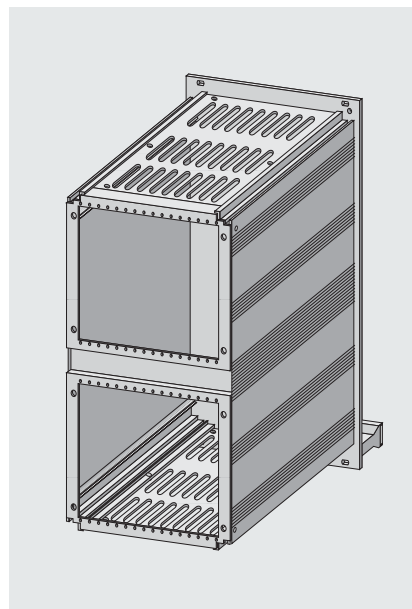

#### Included in delivery

Item	Pc.	Description
1	1	Front panel with plastic handlebar*
2	1	Rear panel
3	2	Aluminium extrusions
4	2	Top / bottom panel, perforated
5		Assembly material

HP	W mm	Part no.	
		D = 170 mm	D = 230 mm
12	60,6	24-8712-50	24-8812-50
14	70,8	24-8714-50	24-8814-50
21	106,3	24-8721-50	24-8821-50
24	121,5	24-8724-50	24-8824-50
28	142,0	24-8728-50	24-8828-50
42	213,0	24-8742-50	24-8842-50

### Cassette 6 U with open sides

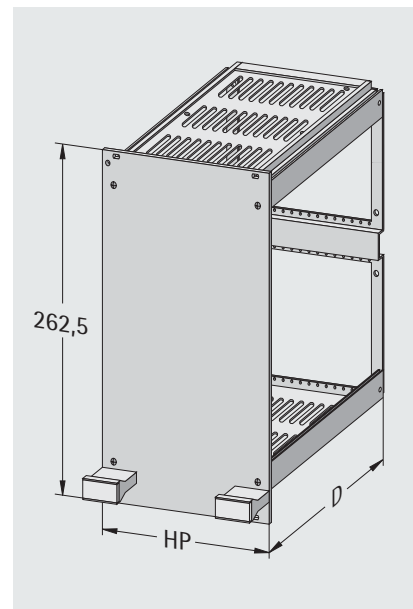

#### Included in delivery

Item	Pc.	Description
1	1	Front panel with plastic handlebar*
2	1	Rear panel
3	4	Aluminium extrusions
4	2	Top / bottom panel, perforated
5		Assembly material

HP	W mm	Part no.	
		D = 170 mm	D = 230 mm
12	60,6	248-712	248-812
14	70,8	248-714	248-814
21	106,3	248-721	248-821
24	121,5	248-724	248-824
28	142,0	248-728	248-828
42	213,0	248-742	248-842

#### Internal card guide

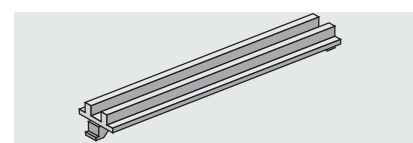

- guides cards inside a cassette

Part no. (1 piece)
250-712



### Model A

PCB is attached to the side of the cassette

Assembly kit A	Part no.
includes: 2x Item 1 2x Item 3 2x Item 8	250-708

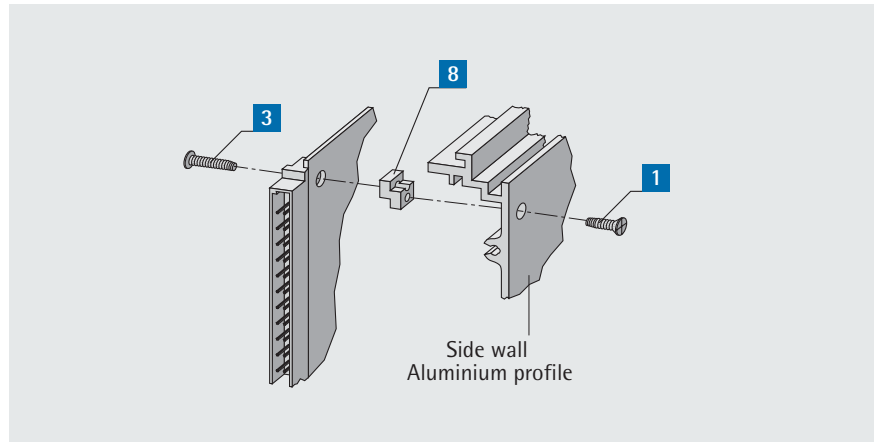

### Model B

PCB is attached to the rear of the cassette

- external wiring

Assembly kit B	Part no.
includes: 2x Item 10 2x Item 5 2x Item 6 2x Item 7	250-709

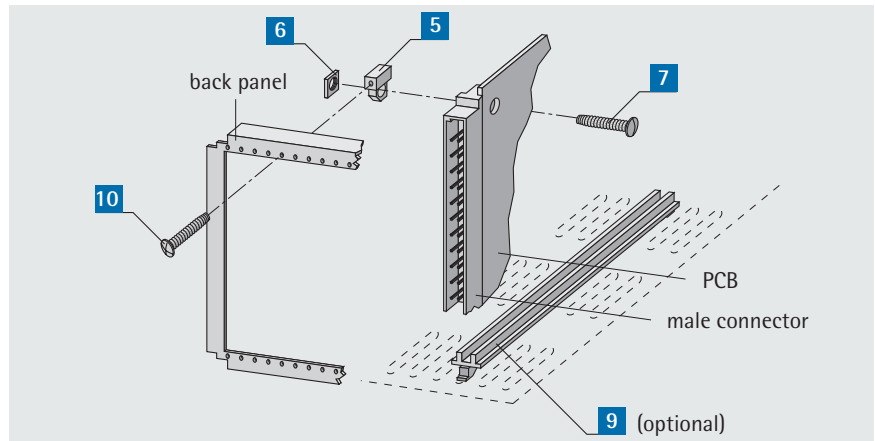

### Model C

PCB is attached to the rear of the cassette

- internal wiring

Assembly kit C	Part no.
includes: 2x Item 1 2x Item 2 2x Item 4 2x Item 6	250-710

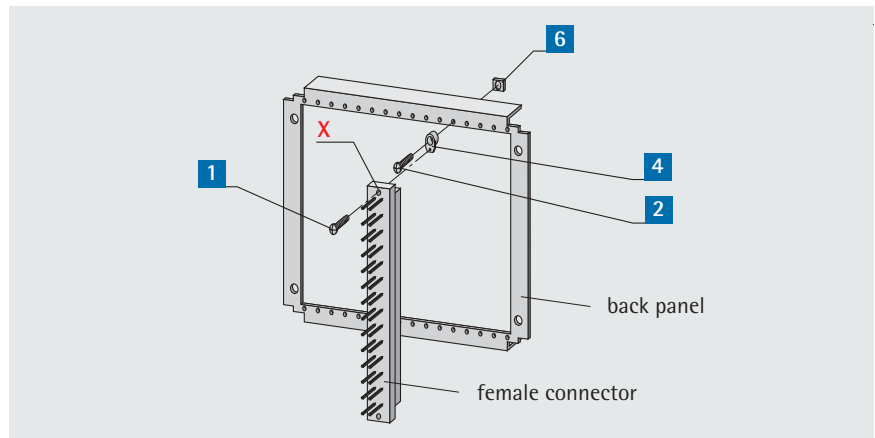

**X** The holes of the female connector must have countersinks. The holes of the male connector are used to attach the male connector to PCB sub-units.

Item	Description	Part no.*	Packing unit
1	Countersunk screw $\varnothing$ 2,2 x 6,5	630-382	100 pieces
2	Countersunk screw M 2,5 x 8	630-127	100 pieces
3	Oval-head screw $\varnothing$ 2,2 x 13	630-383	100 pieces
4	Female connector fixing 32-pole	25-0710-01	1 piece
5	Male connector fixing 32-pole	25-0709-01	1 piece
6	Square nut M 2,5	630-192	100 pieces
7	Oval-head screw M 2,5 x 16	630-080	100 pieces
8	bracket	25-0708-01	1 piece
9	Internal card guide	250-712	1 piece
10	Oval-head screw $\varnothing$ 2,2 x 9,5	630-381	100 pieces

\*Note: Please take note of the quantity of the packing units when ordering individual items